



DNH

HEAD OFFICE, NORWAY
DNH AS

Phone..... + 47 35 98 56 00
Fax..... + 47 35 98 56 10
E-mail..... dnh@dnh.no
Web-Site..... www.dnh.no

ENGLAND
DNH WW Ltd
Phone..... + 44 1908 275 000
Fax..... + 44 1908 275 100
E-mail..... dnh@dnh.co.uk

GERMANY
DNH GmbH
Phone... + 49 040 6569 30-0
Fax..... + 49 040 6569 30-30
E-mail..... dnh@dnh.de

USA
DNH Speakers Inc
Phone..... + 1 484 494 5790
Fax..... + 1 484 494 5793
E-mail..... dnh@dnhspeakers.com

ISO 9001 CERTIFIED

JBP-120

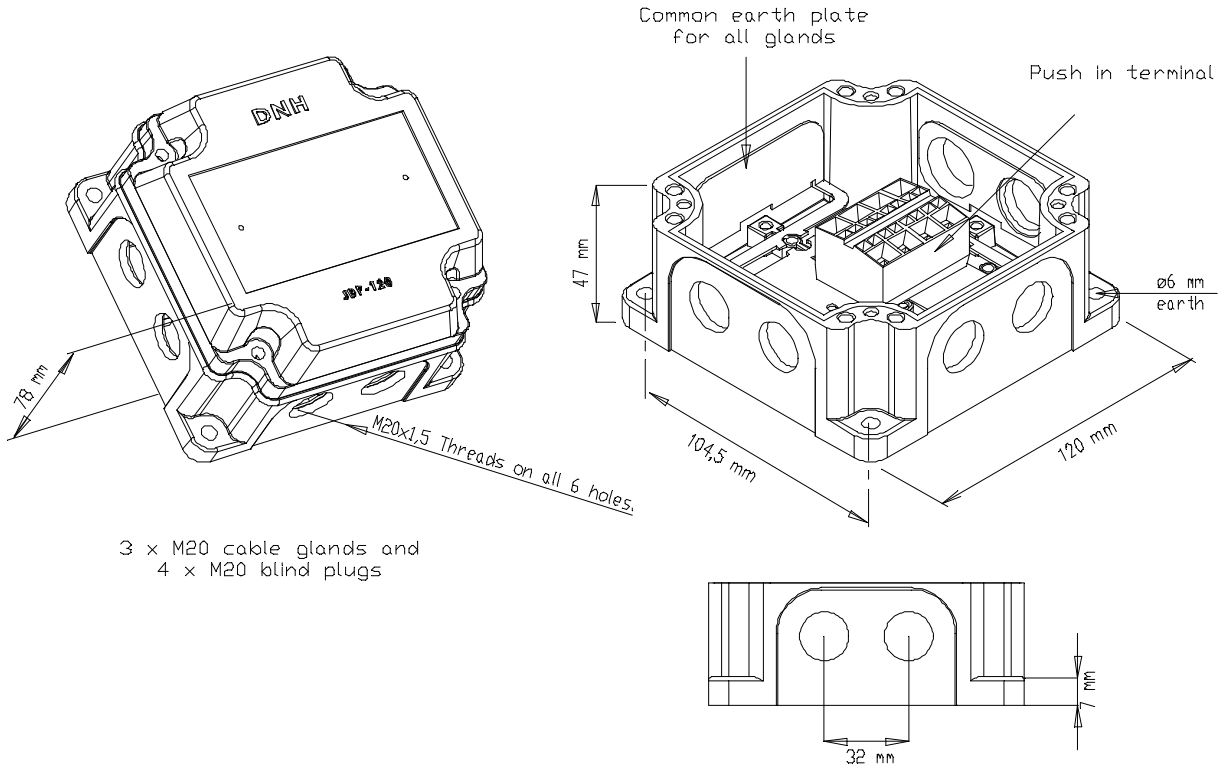

3 x M20 cable glands and
4 x M20 blind plugs

Specifications	
Material / Color	ASA / RAL 7035
Mounting	4 screws
Termination	Wago 264 terminal / earth plate / 2,5 mm ² / 600V
Weight	0,35 kg
IP-rating	67
Max. / min. amb. temp	90°C / -50°C

Installation, Operation and Maintenance Procedures

- Screw the box to the wall or ceiling with 2-4 screws.
- JBP-120 has 6 entries, and is delivered with 3 M-20 Cable glands and 4 M-20 blind plugs with washers.
- Fasten lid with four screws, approximately 1 Nm, use washers on screws.
- JBP-120 is delivered with Wago terminal 264 with max 2,5 mm².
- Junction box has a 2 year warranty against defective workmanship.

DNH reserves the right to alter specifications without notice

